

# Cat® C9 GC DIESEL GENERATOR SETS



Standby: 60Hz, 208V, 480V & 600V



Engine Model	Cat® C9ACERT™ In-line 6, 4-cycle diesel
Bore x Stroke	112mm x 149mm (4.4in x 5.9in)
Displacement	8.8 L (538 in <sup>3</sup> )
Compression Ratio	16.3:1
Aspiration	Turbocharged Air-to-Air Aftercooled
Fuel Injection System	MEUI
Governor	Electronic ADEM™ A4

Standby	Performance Strategy
300 ekW, 375kVA	EPA Certified for Stationary Emergency Application

## PACKAGE PERFORMANCE

Performance	Standby	
Frequency	60 Hz	
Genset Power Rating	375 kVA	
Gen set power rating with fan @ 0.8 power factor	300 ekW	
Fuelling strategy	EPA TIER 3	
Performance Number	DM8168	
Fuel Consumption		
100% load with fan	86.0 L/hr	22.7 gal/hr
75% load with fan	58.8 L/hr	15.5 gal/hr
50% load with fan	43.8 L/hr	11.6 gal/hr
25% load with fan	33.1 L/hr	8.7 gal/hr
Cooling System <sup>1</sup>		
Radiator air flow restriction (system)	0.12 kPa	0.48 in. Water
Radiator air flow	497 m <sup>3</sup> /min	17551 cfm
Engine coolant capacity	14 L	3.69 gal
Radiator coolant capacity	25 L	6.6 gal
Total coolant capacity	45 L	11.88 gal
Inlet Air		
Combustion air inlet flow rate	24.6 m <sup>3</sup> /min	868.7 cfm
Max. Allowable Combustion Air Inlet Temp	49 °C	120 °F
Exhaust System		
Exhaust stack gas temperature	495 °C	923 °F
Exhaust gas flow rate	69.7 m <sup>3</sup> /min	2461 cfm
Exhaust system backpressure (maximum allowable)	10.0 kPa	40.0 in. water
Heat Rejection		
Heat rejection to jacket water	120 kW	6838 Btu/min
Heat rejection to exhaust (total)	320 kW	18223 Btu/min
Heat rejection to aftercooler	92 kW	5239 Btu/min
Heat rejection to atmosphere from engine	23 kW	1312 Btu/min
Heat rejection from alternator	22 kW	1245 Btu/min

Emissions (Nominal) <sup>2</sup>		Standby				
NOx	2371.7 mg/Nm <sup>3</sup>	4.27 g/hp-hr				
CO	216 mg/Nm <sup>3</sup>	0.45 g/hp-hr				
HC	43.7 mg/Nm <sup>3</sup>	0.11 g/hp-hr				
PM	24.8 mg/Nm <sup>3</sup>	0.07 g/hp-hr				
Alternator <sup>3</sup>		Standby				
Voltages	<b>480V</b>	<b>208</b>	<b>600V</b>			
Motor Starting Capability @ 30% Voltage Dip	705	549	1117			
Current	451	1041	361			
Frame Size	M2774L4	M3115L4	M2774L4			
Excitation	S.E	S.E	AREP			
Temperature Rise	105°C	189°F	105°C	189°F	105°C	189°F

## WEIGHTS & DIMENSIONS – OPEN SET

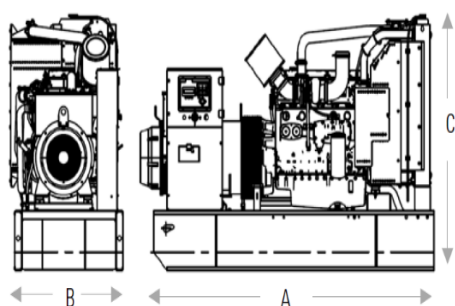

Base	Dim "A" mm (in)	Dim "B" mm (in)	Dim "C" mm (in)	Generator Set Weight kg (lb)
<b>Skid (Wide Base)</b>	3950 (155.5)	1440 (56.7)	1706 (67.2)	2503 (5518.2)
<b>Integral Tank base</b>	3950 (155.5)	1430 (56.3)	2202 (86.7)	3143 (6929.1)

## FUEL TANK CAPACITY

Tank Design	Total Capacity		Useable Capacity	
	Litre	Gallon	Litre	Gallon
<b>Integral</b>	2270	600	2059	544

## DEFINITIONS AND CONDITIONS:

<sup>1</sup> For ambient and altitude capabilities consult your Cat dealer. Air flow restriction (system) is added to existing restriction from factory.

<sup>2</sup> Emissions data measurement procedures are consistent with those described in EPA CFR 40 Part 89, Subpart D & E and ISO8178-1 for measuring HC, CO, PM, NOx. Data shown is based on steady state operating conditions of 77° F, 28.42 in HG and number 2 diesel fuel with 35° API and LHV of 18,390 BTU/lb. The nominal emissions data shown is subject to instrumentation, measurement, facility and engine to engine variations. Emissions data is based on 100% load and thus cannot be used to compare to EPA regulations which use values based on a weighted cycle.

<sup>3</sup> UL 2200 Listed packages may have oversized generators with a different temperature rise and motor starting characteristics. Generator temperature rise is based on a 40° C ambient per NEMA MG1-32.

## APPLICABLE CODES AND STANDARDS:

AS1359, CSA C22.2 No100-04, UL142, UL489, UL869, UL2200, NFPA37, NFPA70, NFPA99, NFPA110, IBC, IEC60034-1, ISO3046, ISO8528, NEMA MG1-22, NEMA MG1-33, 2006/95/EC, 2006/42/EC, 2004/108/EC.

Note: Codes may not be available in all model configurations. Please consult your local Cat Dealer representative for availability.

**STANDBY:** Output available with varying load for the duration of the interruption of the normal source power. Average power output is 70% of the standby power rating. Typical operation is 200 hours per year, with maximum expected usage of 500 hours per year.

**RATINGS:** Ratings are based on SAE J1349 standard conditions. These ratings also apply at ISO3046 standard conditions.

Fuel Rates are based on fuel oil of 35° API (16° C (60° F)) gravity having an LHV of 42 780 kJ/kg (18,390 Btu/lb) when used at 29° C (85° F) and weighing 838.9 g/litre (7.001 lbs/U.S. gal.). Additional ratings may be available for specific customer requirements, contact your Caterpillar representative for details. For information regarding Low Sulfur fuel and Biodiesel capability, please consult your Cat dealer.

LEHE2024-01 (11-19)

[www.Cat.com/electricpower](http://www.Cat.com/electricpower)

©2019 Caterpillar All rights reserved. Materials and specifications are subject to change without notice. The International System of Units (SI) is used in this publication. CAT, CATERPILLAR, their respective logos, "Caterpillar Yellow", the "PowerEdge" and Cat "Modern Hex" trade dress as well as corporate and product identity used here in, are trademarks of Caterpillar and may not be used without permission.